

TECHNICAL BULLETIN
033
May 2026

VBT NEW DESIGN

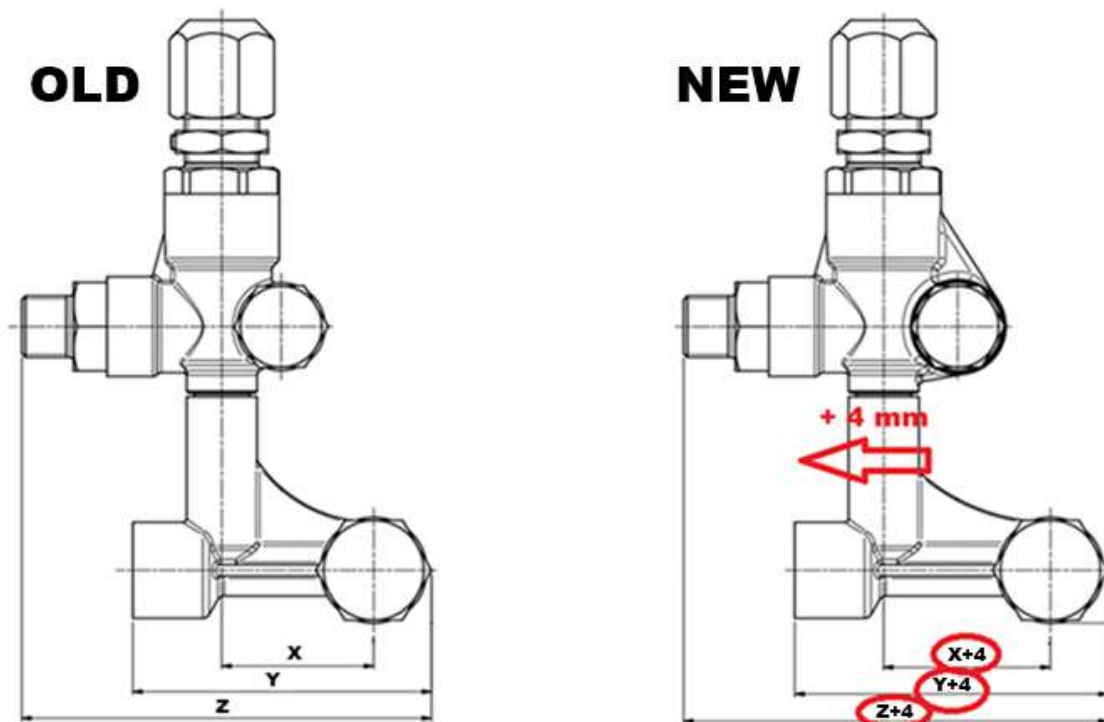

- With a view to continuous improvement, the VBT valve has been modified and reinforced from 2026 onwards.
- This modification has resulted in a noticeable increase in the valve's dimensions. This increase shifts the valve's axis (of the knob) by 4 mm. This shift in the valve's axis is evident not only in the knob's new position, but also in the inlet and outlet, which have also shifted by 4 mm.
- This modification affected the valve body and the by-pass manifold (banjo).
- The individual components (valve body and the by-pass manifold) ARE NOT INTERCHANGEABLE with the previous ones.

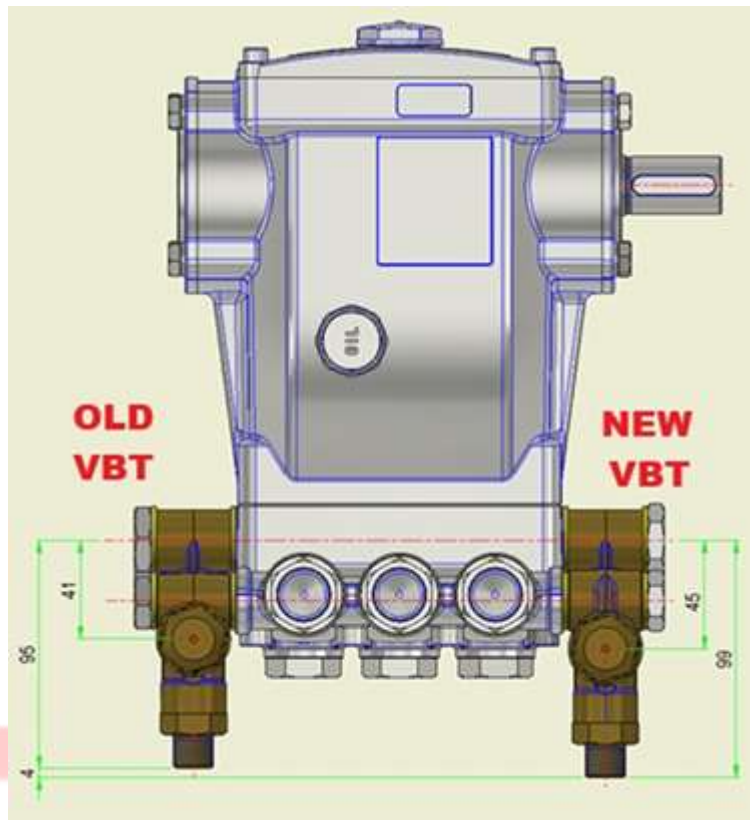

Example code 1.099-486.0

Code	Description	For pumps
1.099-494.0	UNLOADER VALVE VBT G3/8"-G3/8"	FOG
1.904-300.0	VBT UNLOADER VALVE G3/8"-G3/8" BRASS HOLLOW BOLTS	FOG
1.099-485.0	UNLOADER VALVE VBT G1/2"-G3/8"	NHDP
1.099-396.0	VBT UNLOADER VALVE G1/2"-G3/8" BRASS HOLLOW BOLTS	NHDP
1.099-486.0	VBT UNLOADER VALVE G1/2"-G3/8"	NMT
1.904-412.0	VBT UNLOADER VALVE G1/2"-G3/8" BRASS HOLLOW BOLTS	NMT
1.099-487.0	UNLOADER VALVE VBT G1/2"-G3/8"	NPM
1.099-871.0	VBT UNLOADER VALVE G1/2"-G3/8" BRASS HOLLOW BOLTS	NPM

TECHNICAL BULLETIN 033 Maggio 2026

VBT NEW DESIGN

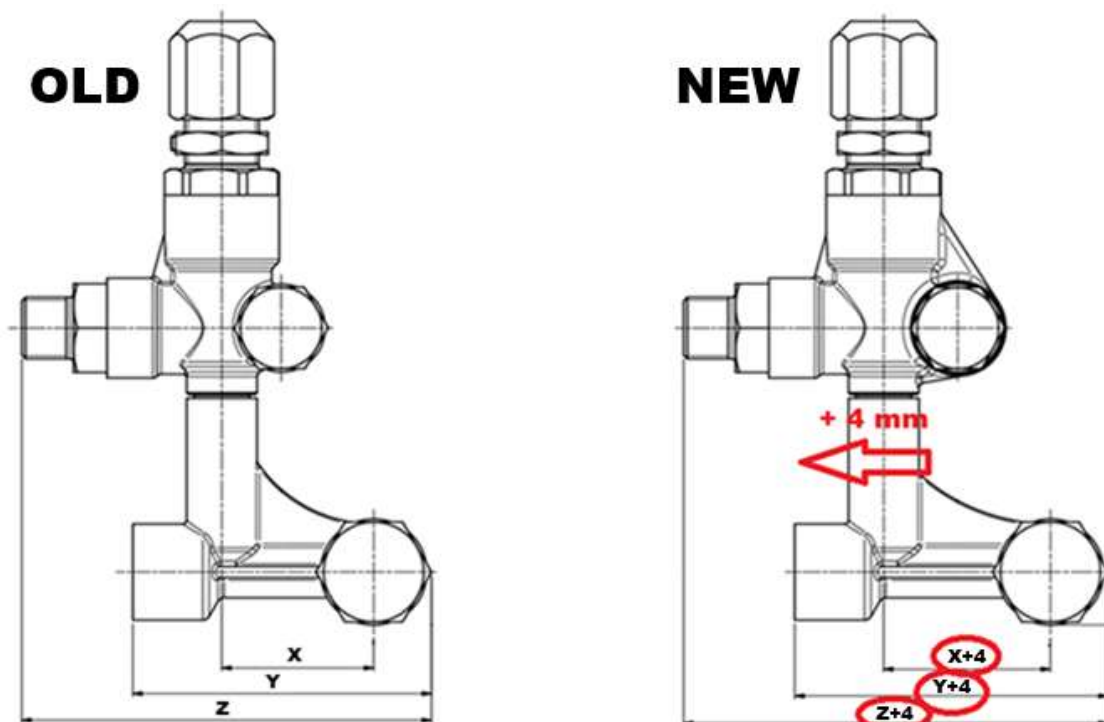

- Dal 2026 la valvola VBT in ottica di un continuo miglioramento è stata modificata e rinforzata.
- Questa modifica ha portato ad un incremento dimensionale percepibile in un aumento dimensionale della valvola. Questo aumento dimensionale sposta l'asse della valvola (della manopola) di 4mm. Questo spostamento dell'asse della valvola è percepibile non solo dalla nuova posizione della manopola, ma anche dall'inlet e dall'outlet che si spostano anch'essi di 4mm
- La modifica ha interessato il corpo ed il collettore by-pass.
- I singoli componenti (corpo e collettore) **NON SONO INTERECAMBIABILI** con i precedenti.

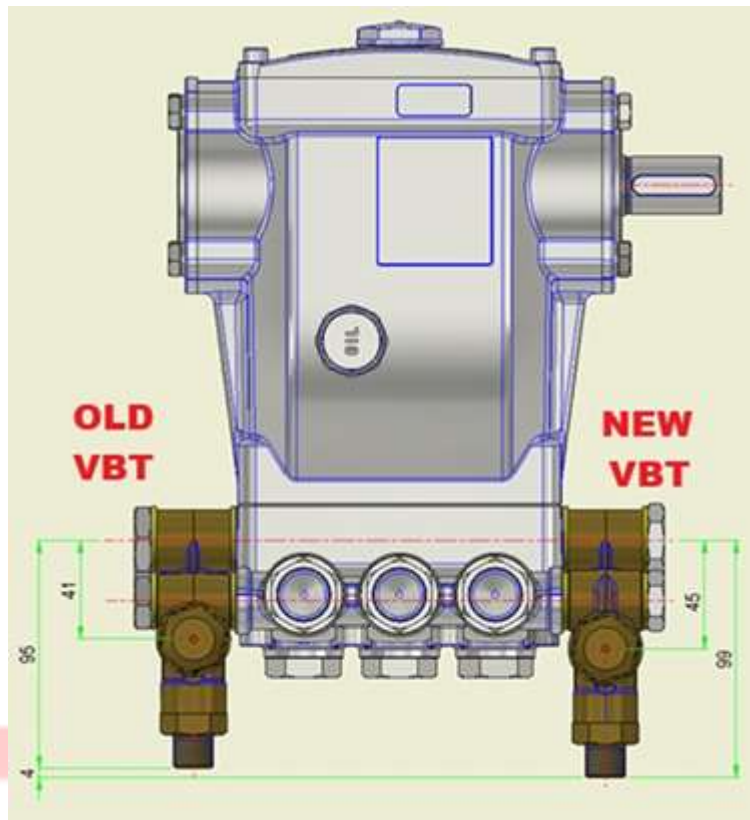

Esempio codice 1.099-486.0

Codice	Descrizione	Per pompe
1.099-494.0	VALVOLA VBT G3/8"-G3/8"	FOG
1.904-300.0	VALVOLA VBT G3/8"-G3/8" VITI OTTONE	FOG
1.099-485.0	VALVOLA VBT G1/2"-G3/8"	NHDP
1.099-396.0	VALVOLA VBT G1/2"-G3/8" VITI OTTONE	NHDP
1.099-486.0	VALVOLA VBT G1/2"-G3/8"	NMT
1.904-412.0	VALVOLA VBT G1/2"-G3/8" NMT VITI OTTONE	NMT
1.099-487.0	VALVOLA VBT G1/2"-G3/8"	NPM
1.099-871.0	VALVOLA VBT G1/2"-G3/8" VITI OTTONE	NPM