

PRESSURE CONTROL VALVES

We are often asked what is the difference between a pressure control valve and an unloader valve. The main function of pressure control valves is to set and maintain constant pressure in the system, acting as the main device for releasing pressure. These valves are used in systems where a continuous outlet flow is required for the whole time the pump is running. It is essential to fit an unloader valve in systems where outlet flow is not required from the nozzle even when the pump is running. This type of valve has the main function of a pressure control valve but it contains a releasing device that redirects the flow through a by-pass line when the outlet on the nozzle is closed (for example via a gun). The by-pass flow can be connected to the source of the system or drained off. When connecting the by-pass to the source, a thermal valve must be fitted for protection against overheating. In this type of system, if there were no way to release the pressure through the by-pass pipe line, there would be an increase in pressure that could endanger the system.

CHOOSING THE VALVE

The choice of valve depends primarily on the type of application and then on whether an unloader version is needed or not. Then take the assembly diagram into consideration. Traditional valves can be fitted and connected with panel mount valves and couplings. With these valves, operation in by-pass mode should not exceed 5 minutes; fitting a temperature sensor is also recommended to prevent the pump from overheating. Traditional versions enable a larger and more flexible number of connections, both on the inlet and by-pass lines, as well as the possibility to have an integrated pressure gauge connection. However, they do have a larger footprint. Last but not least, their dimension is based on pressure and flow rate.

TRADITIONAL
TYPE VALVE

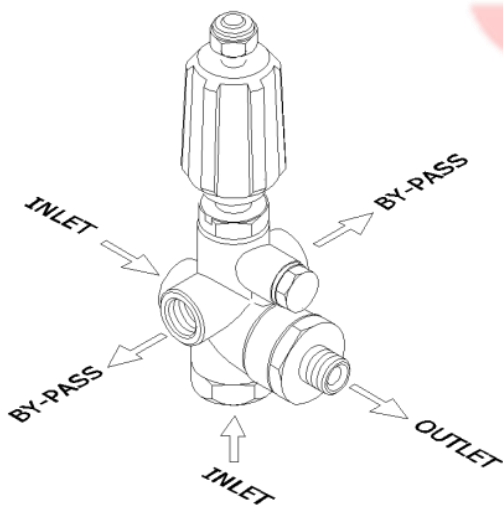

PANEL TYPE
VALVE

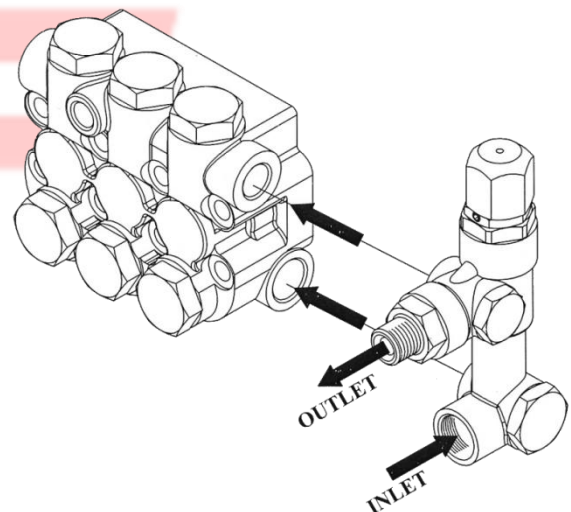

VALVES

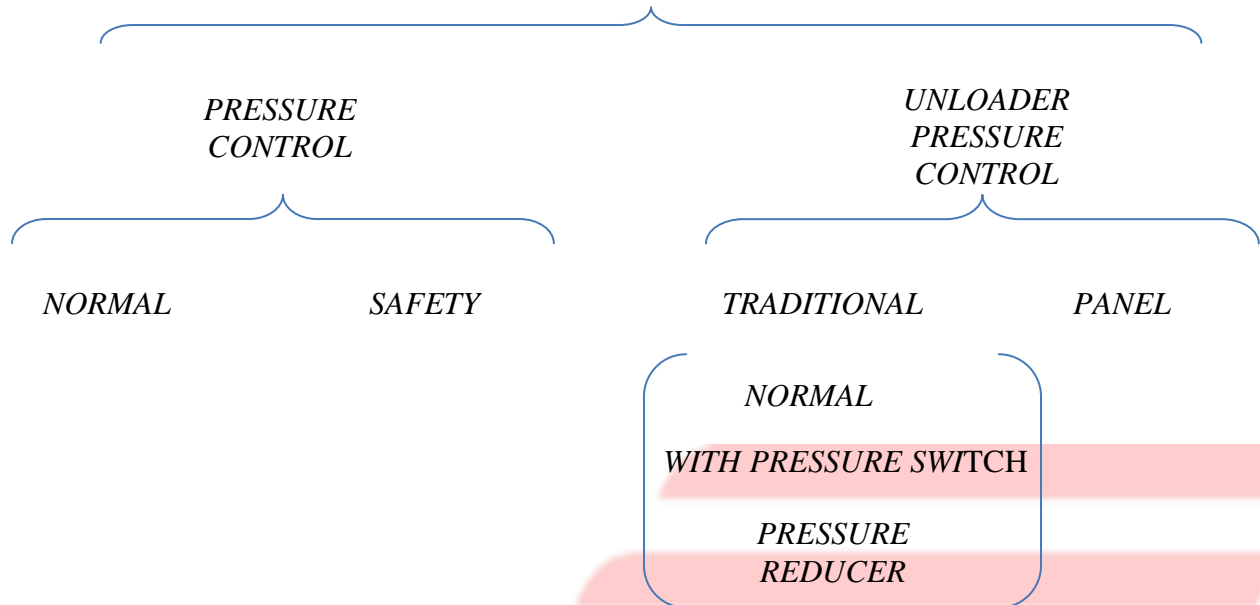

UNLOADER VALVE WITH PRESSURE SWITCH: - pressure control valve, connected to an electromechanical electrically-operated switch, that opens or closes a controlling electric contact when the gun is closed. When the gun is closed, the flow of water is bypassed at low pressure.

PRESSURE REDUCING CONTROL VALVE: Pressure control valve that is able to reduce the pressure between the valve and the gun (with the gun closed) by as much as 30% of the operating pressure. This is useful as it makes the gun extremely manageable. The section upstream to the valve is always at low pressure because of the by-pass.

SAFETY VALVE: - a pressure control valve used for safety reasons; it is a valve that is certified to release all the pressure safely.

INSTALLATION

Fit the valve with suitable couplings and pipes for the pressure and flow rate, avoiding any blockages in the flow. Fit the valve before detergent injectors and burners. Since there is no risk of excessive pressure in case of malfunction. It is advisable to connect the by-pass with sufficiently sized pipes and couplings to enable the free flow and avoid rapid heating of the water during the by-pass phase. However, avoid oversized pipes with respect to the pump flow rate, as a minimum amount of pressure is required in the by-pass circuit. When fitting on machines with a supply tank, connect the by-pass line to this. The by-pass can only be connected to the pump with a direct supply. For applications where the machine will remain in operation with the gun closed for a considerable time, it is advisable to fit a heat protection valve. The valve needs quite clean water to safeguard a long life (avoid sand and rust), fit a suitable filter if necessary.

SETTINGS

With a **PRESSURE CONTROL VALVE**: Adjust the setting when the system is pressurised and the gun open. This does not present any difficulty if you have chosen the right nozzle. When you turn the control knob, the pressure should change. Tighten the counter nut when you have the required pressure. If any parts have been replaced downstream to the valve, turn the control knob to loosen it before starting up the system. At least 5% of the flow rate should be released during delivery in order to avoid pressure spikes when the gun is closed. In order to do this, set the maximum pressure at less than the limit above which further operation of the knob does not have any effect.

With a **MAXIMUM PRESSURE VALVE**: the calibration should ensure the calibrated pressure value is not above the system's maximum operating pressure or of any system accessories.

TOTAL STOP SYSTEM WITH PRESSURE REDUCING VALVES

In a high pressure cleaning system, the use of electromechanical devices such as pressure sensors and flow sensors enables a device commonly known as a "total stop", to be fitted. This automatically stops the pump when the gun is closed and starts it up again when the gun is opened again, without any need for action by the machine operator. If a traditional unloader valve is fitted on the system (pressure trapped unloader or pressure-sensitive valves), the "total stop" system can be based either on pressure sensors or flow sensors indifferently. However, if a pressure reducing unloader valve is fitted on the system (flow sensitive unloader), using two pressure sensors would become worthless due to the reduction of the pressure in the entire line from the pump to the gun. With this type of valve, a total stop system can only be achieved by using a flow sensor. However, in this case the flow sensor must be particularly sensitive to ensure it is also triggered by low flows resulting from the sole pressure of the mains water present in the circuit when the gun is reopened

TROUBLE SHOOTING

PROBLEMS	POSSIBLE CAUSES	SOLUTION
Valve blocks at high pressure	Blocked piston	Clean with care, take care not to scratch the piston and its housing. Replace the piston, if necessary.
	Leak in the circuit downstream to the valve	System maintenance
Valve blocks at low pressure	Worn piston	Replace piston
	Incorrect by-pass assembly	See instructions
	Insufficient flow rate	Check system performance
Pressure knocks on closure	Incorrect valve setting	Adjust the setting as per instructions
	Excessive delivery nozzle wear	Replace
Running intermittently	The setting is below the minimum pressure threshold	Adjust the pressure
	Leak in the circuit downstream to the valve	System maintenance
Rapid heating of the water in by-pass mode	Bottlenecks in the by-pass circuit	Correct the installation
	Flow rate too high	Check the system performance
Failure to reach the maximum pressure envisaged	Worn seals	Replace
	Worn delivery nozzle	Replace
	Insufficient flow rate	Check system performance