

# GUIDE TO TRANSMISSION COMPONENTS

## TYPES OF CONNECTION

There are three methods for connecting a pump to a motor, whatever type of motor it may be.

1. Direct connection
2. Flange and joint connection
3. Pulley connection

### 1. DIRECT CONNECTION

Direct connection is the simplest method but it requires the pump and motor to have a female shaft and there also has to be a coupling flange. Vibration is transferred from the pump to the motor and vice versa.

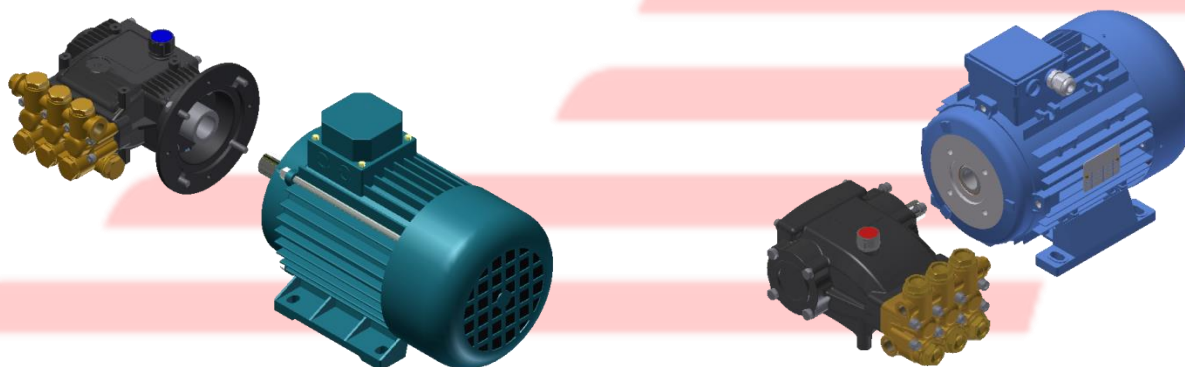

### 2. FLANGE AND JOINT CONNECTION

Flange and joint connection requires the use of an appropriately sized flexible coupling to connect and insulate the pump and motor from vibration.

*In both cases, the rpm is that of the motor. To change the speed, a reduction unit or step up unit must be fitted, or an inverter for electric motors.*

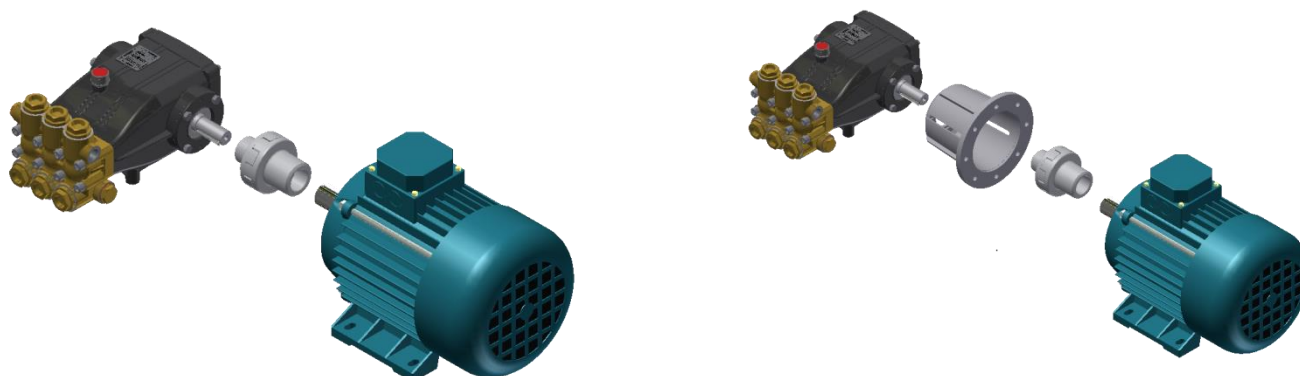

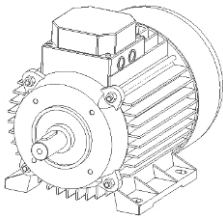
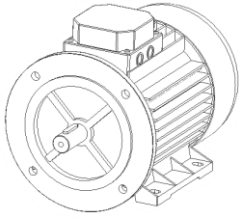
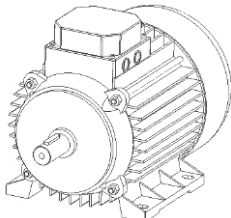
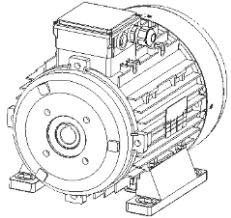
			
<b>B3/B14 (B34) Motor</b>	<b>B3/B5 (B35) Motor</b>	<b>B3 Motor</b>	<b>Hollow shaft motor</b>
Suitable for joint and flange- or direct connections with a pump with flange and hollow shaft	Suitable for joint and flange connections	Suitable for joint only connections or with pulleys	Suitable for direct coupling without joint and/or flange
<b>NOTE:</b> Make sure the dimension of the pump flange is compatible with that of the motor			

### 3. PULLEYS

The third case uses pulleys; this has the advantage of isolating the pump and motor from vibration and of being able to determine the required rpm with ease.

There is a wide variety of belts and pulleys available; a brief overview is provided below.

The pulleys should be fitted as close to the pump crankcase as possible to avoid generating excessive twisting forces due to the pull of the belts.



The following data is required to ensure optimum transmission dimensioning:

- a) MOTOR
  - Type of motor
  - Power
  - Number of rpm/1'
- b) PUMP
  - Type of pump
  - Power consumption
  - Number of rpm/1'
- c) TYPE OF OPERATION
  - Intermittent, continuous, seasonal, etc.
  - Hours per day
- d) SIZE
  - Maximum diameter
  - Axial dimensions
  - c/c

- Effective output  $P_c = P * F_s$  ;where  $F_s$  is the service factor (refer to the pulley manufacturer's catalogue)

- Transmission ratio  $K = \frac{n_1}{n_2}$  ;where  $n_1$  and  $n_2$  are the RPM of the pump and motor respectively

- The calculation of the primitive development of the belt and the effective c/c

$$L_t = 2 * I_t + 1,57 * (D_p + d_p) + \frac{(D_p - d_p)^2}{4 + I_t}$$

- The effective c/c  $I_e = I_t \pm \frac{L_p - L_t}{2}$

- The transmitted power  $P_a = (P_b + P_d) * C_y * C_L$

- The number of belts in the system  $Q = \frac{P_c}{P_a}$

$L_t$  = theoretical pitch length of the belt (mm)  
 $I_t$  = theoretical c/c (mm)  
 $D_p$  = pitch diameter of the major pulley (mm)  
 $d_p$  = pitch diameter of the minor pulley (mm)  
 $L_p$  = Actual pitch length of the belt (mm)  
 $I_e$  = Actual c/c (mm)  
 $P_b$  = basic performance in kW based on the pitch diameter and the number of rpm of the minor pulley  
 $P_d$  = differential performance in kW, based on the transmission ratio  
 $C_y$  = Correction factor for contact arcs, on the minor pulley, below 180 ° (specification of the chosen belt)  
 $C_L$  = Correction factor based on the type and length of the belt (specification of the chosen belt)

## MECHANICAL INSTALLATION

Should the flange and joint system be used (available for different models), proper coupling is guaranteed by the precision machining of the components; this also applies when reduction units or step up units are used. With this type of coupling, make sure only the motor is secured to the assembly base, possibly by applying silent blocks to the feet and leaving the pump overhanging.

With belt and pulley coupling, pay particular attention to the alignment of the pulleys and adjust the belt tension carefully (the motor must be mounted on a specific belt tensioning sled with adjustable screw). Excessive belt tension can cause the oil to overheat and reduce bearing life. Refer to the technical documentation supplied by the drive belt manufacturers for details of the dimensioning of the pulleys and belts.

Direct coupling with a flexible coupling, but without a flange, is more challenging. In this case, both the pump and the motor are secured to the assembly block. Before coupling the machines with the joint, the two shafts must be perfectly aligned using shims under the feet of the pump or motor, if necessary. This is to avoid forcing the pump and motor bearings. With a joint or belt and pulley connection to the pump, all exposed revolving parts must be protected with an appropriately dimensioned joint cover and belt cover to avoid accidents.

## GEARBOXES

A gearbox is an alternative to the pulley system for changing the number of rpm of pump operation. Rpm reduction units and step up units are available on the market.

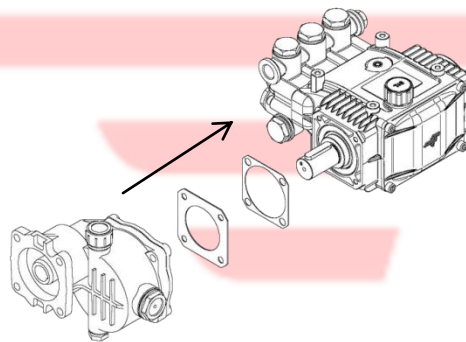

**WARNING:** *Never exceed the rotation values for the pump*

Reduction units and step up units can be used to alter the rpm of the pump by a fixed factor, known as the reduction or multiplication ratio. The choice of the type of gearbox depends on the power to transmit and the required rpm.

Gearboxes are usually designed for coupling to endothermic motors.

Follow the instructions provided in the supplier's manual for dimensioning and maintenance.